

PRODUCT DATA



MZS-104 Zoom Camera Unit

General specifications:

Power input: 12-15V DC

Weight: 1851 g

Idle power consumption: 1,44W

Peak power consumption (zoom): 3W

Viewing angle: Vertical (adjustable via nuts)

Housing material: Aluminum

Housing dimensions: 90x90x230mm (LxWxH)

Zoom factor: 22x optical

1200TVL PAL System, resolution: 1,3 MP

Nitrogen filled inner housing: IP67

Functionality:

This camera unit is specifically designed for trolley tower crane operations, providing a bird's-eye view from above.

With its reliable functionality, it enhances visibility and safety on-site.

The transmitter unit is integrated and the whole trolley set can be operated throughout the whole year on pure solar energy.

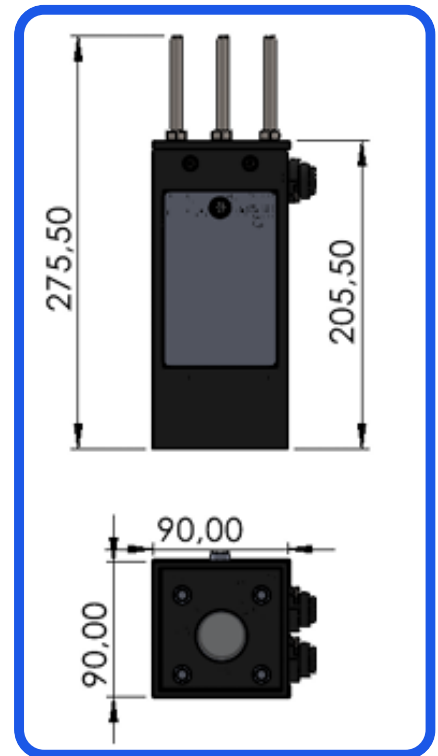
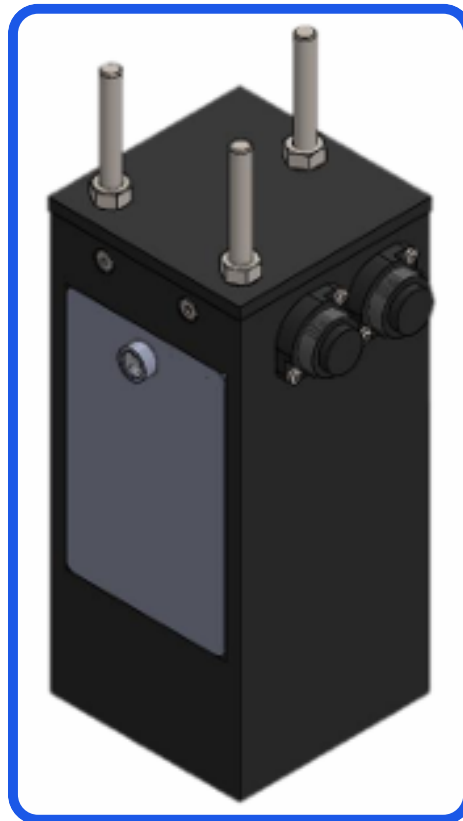

More Information:

✉ info@cranecamera.eu

🌐 www.cranecamera.eu

Office: ☎ +31 33 466 8938

Service: ☎ +31 6 159 561 05

BCS
CRANECAMERA